



Republic of the Philippines
ENERGY REGULATORY COMMISSION
San Miguel Avenue, Pasig City

RESOLUTION NO. 09, SERIES OF 2013

**A RESOLUTION ADOPTING THE RULES ENABLING
THE NET-METERING PROGRAM FOR RENEWABLE
ENERGY**

WHEREAS, it is the policy of the state to accelerate the exploration and development of renewable energy resources, increase its utilization and establish the necessary infrastructure and mechanisms;

WHEREAS, Section 10 of Republic Act No. 9513 (R.A. 9513), entitled "An Act Promoting the Development, Utilization and Commercialization of Renewable Energy Resources and for Other Purposes," and Section 7 of its Implementing Rules and Regulations (IRR) mandate the Energy Regulatory Commission (ERC), in consultation with the National Renewable Energy Board (NREB), to establish, within one (1) year from effectivity of the Act, the net-metering interconnection standards and pricing methodology and other commercial arrangements necessary to ensure the success of the net-metering for renewable energy program;

WHEREAS, Section 10 of R.A. 9513 further provides that the Department of Energy (DOE), ERC, National Transmission Corporation (TRANSCO) or its successors-in-interest, Distribution Utilities (DUs), Philippine Electricity Market Corporation (PEMC) and all relevant parties shall provide the mechanism for the physical connection and commercial arrangements necessary to ensure the success of the program, consistent with the Philippine Grid Code (PGC) and the Philippine Distribution Code (PDC);

WHEREAS, on April 12, 2012, the NREB transmitted to the ERC its proposed Rules Enabling the Net-Metering Program for Renewable Energy, and made a presentation thereon to the ERC on July 3, 2012;

WHEREAS, the proposed Rules already incorporate the proposed preliminary Pricing Methodology for Net-Metering, as well as the Net-Metering Interconnection Standards and Net Metering Agreement template;

WHEREAS, on August 28, 2012, the ERC approved the posting of the proposed Rules and set the deadline for the submission of comments on September 10, 2012 and the public consultation on September 21, 2012 at the ERC Head Office, Pacific Center Building, San Miguel Avenue, Ortigas Center, Pasig City;

WHEREAS, the following stakeholders submitted their comments on the proposed Rules, and were therefore considered as parties of record during the public consultation: (1) Cagayan Electric Power and Light Company, Inc. (CEPALCO); (2) Distribution Management Committee (DMC); (3) Enfinity Philippine Renewable Resources, Inc.; (4) Manila Electric Company (MERALCO); (5) Philippine Electricity Market Corporation (PEMC); (6) Philippine Sugar Millers Association (PSMA); (7) SMA (Inverter Manufacturer); and (8) Visayan Electric Company (VECO);

WHEREAS, the ERC-Technical Working Group for Renewable Energy and the NREB-Technical Working Group for Net-Metering conducted several coordination meetings/workshops with relevant stakeholders to clarify and discuss possible revisions to the proposed Rules;

WHEREAS, after careful consideration of the comments submitted by interested parties, the ERC deems it appropriate to adopt and implement the Rules Enabling the Net-Metering Program for Renewable Energy;

NOW THEREFORE, the ERC, after thorough and due deliberation, hereby **RESOLVES**, as it is hereby **RESOLVED**, to **APPROVE** and **ADOPT**, the "**Rules Enabling the Net-Metering Program for Renewable Energy**" hereto attached as **Annex "A"** and made an integral part hereof.

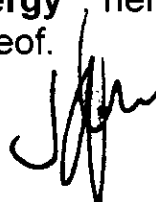

This Resolution shall take effect fifteen (15) days after its publication in a newspaper of general circulation in the country.

Let copies of this Resolution be furnished the University of the Philippines Law Center – Office of the National Administrative Register (UPLC-ONAR) and all parties concerned.

Pasig City, 27 May 2013.

ZENAIDA G. CRUZ-DUCUT
Chairperson *gmdr*

**MARIA TERESA A.R.
CASTAÑEDA**
Commissioner

JOSE C. REYES
Commissioner

ALFREDO J. NON
Commissioner

**GLORIA VICTORIA C. YAP-
TARUC**
Commissioner

RULES ENABLING THE NET-METERING PROGRAM FOR RENEWABLE ENERGY

ARTICLE I - GENERAL PROVISIONS

Section 1. Net-Metering for Renewable Energy. Subject to technical considerations and without discrimination, and upon request by distribution end-users, the Distribution Utilities (DUs) shall enter into net-metering agreements with qualified end-users who will be installing an RE system.

Section 2. Purpose. These Rules seek to:

- a) Encourage end-users to participate in renewable electricity generation;
- b) Enable data-gathering for the creation of a knowledge-based resource on net-metering, and enhance or accelerate viability of net-metering program and its successful integration to the grid; and
- c) Allow local players to gain actual experience and the confidence in installing RE systems for net-metering application under local conditions.

Section 3. Applicability. These Rules shall be applicable to On-Grid Systems.

Section 4. Definition of Terms. As used in these Rules, the following terms shall have the following meaning:

- (a) **Department of Energy (DOE)** refers to, as defined in Section 4(e) of Republic Act No. 9513, the government agency created pursuant to Republic Act No. 7638 whose functions are expanded in Republic Act No. 9136 and further expanded in Republic Act No. 9513.
- (b) **Distributed Generation** refers to a system of small generation entities supplying directly to the distribution grid, any one of which shall not exceed one hundred kilowatts (100 kW) in capacity, as defined in Section 4(j) of Republic Act No. 9513.

- (c) **Distribution System** refers to the system of wires and associated facilities belonging to a franchised distribution utility extending between the delivery points on the transmission or subtransmission system or generator connection and the point of connection to the premises of the end-user, as defined in Section 4(o) of Republic Act No. 9136.
- (d) **Distribution Services and Open Access Rules (DSOAR)** refers to the Rules promulgated by the Energy Regulatory Commission under ERC Resolution No. 2, Series of 2010 including any subsequent amendments thereto, covering, among others, the terms and conditions for the connection of generating facilities to the Distribution System.
- (e) **Distribution Utility (DU)** refers to any electric cooperative, private corporation, government-owned utility or existing local government unit which has an exclusive franchise to operate a Distribution System in accordance with its franchise and R.A. No. 9136, as defined in Section 4(l) of Republic Act No. 9513.
- (f) **Energy Regulatory Commission (ERC)** refers to the independent quasi-judicial regulatory agency created pursuant to Republic Act No. 9136, as defined in Section 4(n) of Republic Act No. 9513.
- (g) **End-User** refers to any person or entity requiring the supply and delivery of electricity for its own use, as defined in Section 4(t) of Republic Act No. 9136.
- (h) **Export Energy** refers to the energy exported or delivered by the Qualified End-user to the Grid/Distribution System.
- (i) **Import Energy** refers to the energy imported or received by the Qualified End-user from the Grid/Distribution System.
- (j) **Metering Service Provider (MSP)** refers to a person or entity authorized by ERC to provide Metering Services. The DU shall be the sole metering service provider for the retail market until such time that the ERC determines the provision of metering services at the retail level as competitive.
- (k) **National Power Corporation (NPC)** refers to the government corporation created under Republic Act No. 6395 as amended

by Republic Act No. 9136, as defined in Section 4(ee) of Republic Act No. 9513.

- (l) **National Renewable Energy Board (NREB)** refers to the board created under Republic Act No. 9513 tasked under Section 10 thereof to recommend to ERC the establishment of net-metering interconnection standards, pricing methodology and other commercial arrangements necessary to ensure success of the net-metering for renewable energy program.
- (m) **National Transmission Corporation (TRANSCO)** refers to the corporation created pursuant to Republic Act No. 9136 responsible for the planning, construction and centralized operation and maintenance of high voltage transmission facilities, including interconnection and ancillary services, as defined in Section 4(ff) of Republic Act No. 9513.
- (n) **Net-Metering** refers to a system, appropriate for distributed generation, in which a distribution grid user has a two-way connection to the grid and is only charged or credited, as the case may be, the difference between its import energy and export energy.
- (o) **Net-Metering Agreement** refers to the agreement between a Qualified End-User (QE) and the DU governing the commercial and interconnection arrangements between the DU and the QE.
- (p) **Net-Metering Interconnection Standards** refers to the set of requirements and procedures to ensure safe, reliable and efficient connection of QE's RE system, and its operation thereof in parallel to the Distribution System.
- (q) **On-Grid Systems** refers to electrical systems composed of interconnected transmission lines, distribution lines, substations and related facilities for the purpose of conveyance of bulk power on the grid of the Philippines, as defined in Section 4(kk) of Republic Act No. 9513.
- (r) **Philippine Distribution Code (PDC)** refers to the set of Rules, requirements, procedures and standards governing DUs and Users of Distribution System in the operation, maintenance and development of the Distribution System. It also defines and establishes the relationship of the Distribution System with the facilities or installations of the parties connected thereto.

- (s) **Philippine Electrical Code (PEC)** refers to the electrical safety Code that establishes basic materials quality and electrical work standards for the safe use of electricity for light, heat, power, communications, signaling, and for other purposes.
- (t) **Philippine Electricity Market Corporation (PEMC)** refers to the Corporation incorporated upon the initiative of the DOE which administers and governs the operation of the Wholesale Electricity Spot Market (WESM).
- (u) **Qualified End-Users (QE)** refers to entities that generate electric power from an eligible on-site RE generating facility, such as, but not limited to, house or office building with photovoltaic system that can be connected to the grid, for the purposes of entering into a Net-Metering agreement, as defined in Section 7 of the Implementing Rules and Regulations of R.A. 9513.
- (v) **Renewable Energy (RE) Certificate** refers to a certificate issued by the RE Registrar to electric power industry participants showing the energy sourced, produced, and sold or used. RE Certificates may be traded in the RE Market in complying with the RPS, as defined in Section 3(tt) of the Implementing Rules and Regulations of R.A. 9513.
- (w) **Renewable Energy Market (REM)** refers to the market where the trading of RE Certificates equivalent to an amount of power generated from RE Resources is made, as defined in Section 4(qq) of Republic Act No. 9513.
- (x) **Renewable Energy Resources (RE Resources)** refers to energy resources that do not have an upper limit on the total quantity to be used. Such resources are renewable on a regular basis, and whose renewal rate is relatively rapid to consider availability over an indefinite period of time. These include, among others, biomass, solar, wind, geothermal, ocean energy, and hydropower conforming with internationally accepted norms and standards on dams, and other emerging renewable energy technologies, as defined in Section 4(uu) of Republic Act No. 9513.
- (y) **Renewable Portfolio Standards (RPS)** refers to a market-based policy that requires electric power industry participants,

including suppliers, to source a portion of their energy supply from eligible RE Resources, as defined in Section 4(ss) of Republic Act No. 9513.

- (z) **Renewable Energy Systems (RE Systems)** refers to energy systems which convert RE resources into useful energy forms, like electrical, mechanical, etc., as defined in Section 4(vv) of Republic Act No. 9513.
- (aa) **Wholesale Electricity Spot Market (WESM)** refers to the wholesale electricity spot market created pursuant to Republic Act No. 9136, as defined in Section 4(eee) of Republic Act No. 9513.

ARTICLE II - QUALIFICATIONS AND ELIGIBILITY

Section 5. Qualifications. All end-users who are in good credit standing in the payment of their electric bills to the DU are qualified to participate in the Net-Metering program for Renewable Energy.

Section 6. Eligible RE Technologies. RE Systems such as wind, solar, biomass or biogas energy systems or such other RE Systems capable of being installed within the QE's premises are eligible to participate in the net-metering program.

ARTICLE III – INTERCONNECTION STANDARDS

Section 7. Mandated Entities. As provided in Section 10 of Republic Act No. 9513, the DOE, ERC, TransCo or its successor-in-interest, DUs, PEMC and all relevant parties are mandated to provide mechanisms for the physical connection and commercial arrangements necessary to ensure the success of net-metering for renewable energy program, consistent with the Grid and Distribution Codes.

The DUs and the QEs shall, upon request, grant ERC, DOE and NREB free access to all data generated by net-metering to enable the creation of a knowledge-based resource on net-metering, and enhance or accelerate viability of the net-metering program and successful integration to the grid.

Section 8. Compliance Standards. The RE System to be installed within the QE's premises must be compliant with the standards set by

Philippine Electrical Code (PEC), Philippine Distribution Code (PDC), Distribution Service Open Access Rules (DSOAR) and the Net-Metering Interconnection Standards (See Annex "A-1").

Section 9. Interconnection Set-Up. The RE system shall be embedded in the QE's premises and shall be equipped with appropriate metering equipment. The DU shall install two uni-directional meters, one for import and one for export, or a single bi-directional meter, whichever is more economical on a case-to-case basis. The DU may, at any time, also install a third meter in proximity to the RE System to measure the total RE generated.

Section 10. DU Inspection. The QE shall allow the DU to enter the QE's premises to inspect, test, maintain and operate the protective devices and read or test the meters and other facilities. The DU may also disconnect the interconnection facilities if it reasonably believes a hazardous condition exists and such immediate action is necessary to protect persons, or the DU's facilities or property of others, damage or interference caused by the QE's facilities, or lack of properly operating protective devices; provided, that prior notice is given of the intent to disconnect, and the QE is given at least three (3) days within which to remedy the hazardous condition.

ARTICLE IV – COMMERCIAL ARRANGEMENTS

Section 11. Net-Metering Agreement. Subject to technical considerations and without discrimination and upon request by a QE, the DU shall enter into a Net-Metering Agreement with the requesting QE (See Annex "A-2"). Thereafter, the DU shall furnish the executed Net-Metering Agreement to ERC, DOE and NREB, within five (5) days from its execution. The executed Net-Metering Agreement shall be deemed approved and effective upon submission thereof to ERC.

Section 12. Pricing Methodology. The ERC, in consultation with the NREB and the electric power industry participants, shall establish in a subsequent issuance a pricing methodology applicable to net-metering. Meantime, the DU's monthly generation charge, which is based on its blended generation cost, shall be used as the preliminary reference price in net-metering agreements. In case of DUs with special programs, the applicable preliminary reference price shall be the generation charge it imposes on its regular captive market, which is based on its blended generation cost excluding other generation adjustments.

Section 13. Cost Recovery of Net-Metering Agreements. The cost of RE exported to the DU system and purchased by the DU under net-metering agreements shall automatically be included in the DU's total generation cost to be recovered from all DU customers as part of the adjusted generation rate pursuant to Section 2, Article 2 of ERC Resolution No. 19, Series of 2009.

Section 14. Net-Metering Charge - The DUs shall impose a net-metering charge to all customers who avail of the Net-Metering program equivalent to their existing ERC-approved Php/customer/month supply and metering rates; plus the existing ERC-approved Php/kilowatthour metering rate based on the export energy to the Distribution System as registered in the export meter. This Net-Metering Charge shall cover the incremental costs related to system enhancement and additional meter reading and other operating costs.

The DUs may file with the ERC their applications for approval of different Net-Metering Charges for Net-Metering customers in accordance with Section 4 (e), Rule 3 of the IRR of the EPIRA, and Rule 6 of the ERC Rules of Practice and Procedure. Meantime, the Net-Metering Charges as provided above shall be effective until a different charge is approved by the ERC, upon application by the DUs.

Section 15. Billing Charges. The net amount payable by or creditable to the QE shall be obtained by subtracting from the subtotal amount for import energy, the following: (a) the subtotal peso amount for export energy, and (b) the peso amount credited in the previous month, if any. If the resulting peso amount is positive, QE shall pay this positive peso amount to the DU. If the resulting peso amount is negative, the DU shall credit the negative peso amount to the QE's electric bill in the immediately succeeding billing period.

Section 16. RE Certificate. The DU shall be entitled to any RE Certificate resulting from Net-Metering arrangements with the QE who is using an RE Resource to provide energy. Such RE Certificate shall be based on gross generation and shall be credited in compliance of the DU's obligations under the RPS.

Section 17. Final Provisions

17.1. Exception Clause. Where good cause appears, the ERC may allow an exemption from any provision of these Rules, if such is

found to be in the public interest and is not contrary to law or any other related rules and regulations.

17.2. Separability Clause. If any provision of these Rules is declared invalid or unconstitutional by a court of competent jurisdiction, those provisions which are not affected thereby shall continue to be in full force and effect.

17.3. Repealing. All prior rules and guidelines or portion thereof, issued by the ERC that are inconsistent with these Rules are hereby repealed or modified accordingly.

17.4. Effectivity. These Rules shall take effect within fifteen (15) days following its complete publication in a newspaper of general circulation.

Pasig City, 27 May 2013.

ZENAIDA G. CRUZ-DUCUT
Chairperson

MARIA TERESA A.R. CASTAÑEDA
Commissioner

JOSE C. REYES
Commissioner

ALFREDO J. NON
Commissioner

GLORIA VICTORIA C. YAP-TARUC
Commissioner

sum
4

ANNEX "A-1"

NET-METERING INTERCONNECTION STANDARDS

TABLE OF CONTENTS

	PAGE NO.
1. OVERVIEW	3
2. SCOPE AND PURPOSES	3
3. DEFINITIONS	3
4. GENERAL GUIDELINES	6
5. APPLICATION FOR INTERCONNECTION	7
6. SYSTEM PARAMETERS	8
7. SYSTEM PROTECTION	10
8. OPERATIONS & MAINTENANCE	13
9. METERING	13
10. TESTING AND COMMISSIONING	14
11. BIBLIOGRAPHY	16
12. APPENDIX	18

1. OVERVIEW

These guidelines set forth the Net-Metering Interconnection Standards for Qualified End-users (QE) who enter into Net-metering Agreements with on-grid Distribution Utilities (DUs).

2. SCOPE AND PURPOSES

These guidelines cover distributed generation, which is connected to and operates in synchronism with the on-grid DUs, and apply to single-phase or three-phase generation with a maximum capacity of 100 kW.

These guidelines establish the rules and standards for the interconnection of RE generating facilities to the DU's Distribution System. They provide technical guidance to address engineering, electric system reliability, and safety concerns for net-metering interconnections.

3. DEFINITIONS

The following terms shall be understood to have the following meanings when used in these guidelines.

- 3.1. **Commissioning Test** refers to a test conducted when the equipment is installed to verify correct operation.
- 3.2. **Connection Point** refers to the point of connection of the QE System or Equipment to the Distribution System.
- 3.3. **Distributed Generation** refers to a system of small generation entities supplying directly to the distribution grid, any one of which shall not exceed one hundred kilowatts (100 kW) in capacity, as defined in Section 4(j) of Republic Act No. 9513.
- 3.4. **Distribution Asset Study (DAS)** refers to a study to determine all distribution assets and costs necessary to accommodate a proposed net-metering interconnection.
- 3.5. **Distribution Impact Study (DIS)** refers to a set of technical studies which are used to assess the possible effects of a proposed expansion, reinforcement, or modification of the

Distribution System or a User Development and to evaluate Significant Incidents.

- 3.6. **Distribution Services and Open Access Rules (DSOAR)** refers to the Rules promulgated by the Energy Regulatory Commission under ERC Resolution No. 2, Series of 2010 including any subsequent amendments thereto, covering, among others, the terms and conditions for the connection of generating facilities to the Distribution System.
- 3.7. **Distribution System** refers to the system of wires and associated facilities belonging to a franchised distribution utility extending between the delivery points on the transmission or subtransmission system or generator connection and the point of connection to the premises of the end-user, as defined in Section 4(o) of Republic Act No. 9136.
- 3.8. **Distribution Utility (DU)** refers to any electric cooperative, private corporation, government-owned utility or existing local government unit which has an exclusive franchise to operate a Distribution System in accordance with its franchise and R.A. No. 9136, as defined in Section 4(l) of Republic Act No. 9513.
- 3.9. **Energy Regulatory Commission (ERC)** refers to the independent quasi-judicial regulatory agency created pursuant to Republic Act No. 9136, as defined in Section 4(n) of Republic Act No. 9513.
- 3.10. **Interconnection** refers to the result of the process of adding a RE facility to the Distribution System.
- 3.11. **Island** refers to a condition in which a portion of the DU's distribution network is energized solely by one or more RE facilities.
- 3.12. **Metering Service Provider (MSP)** refers to a person or entity authorized by ERC to provide Metering Services. The DU shall be the sole metering service provider for the retail market until such time that the ERC determines the provision of metering services at the retail level as competitive.
- 3.13. **Net-Metering** refers to a system, appropriate for distributed generation, in which a distribution grid user has a two-way connection to the grid and is only charged or credited, as the

case may be, the difference between its import energy and export energy.

- 3.14. **Net-Metering Agreement** refers to the agreement between a QE and the DU governing the commercial and inter-connection arrangements between the DU and the QE (See Annex "A-2").
- 3.15. **Parallel Operation** refers to the operation of an RE facility with or without an exporting capacity while connected to DU's Distribution System.
- 3.16. **Philippine Distribution Code (PDC)** refers to the set of Rules, requirements, procedures and standards governing DUs and Users of Distribution System in the operation, maintenance and development of the Distribution System. It also defines and establishes the relationship of the Distribution System with the facilities or installations of the parties connected thereto.
- 3.17. **Philippine Electrical Code (PEC)** refers to the electrical safety Code that establishes basic materials quality and electrical work standards for the safe use of electricity for light, heat, power, communications, signaling, and for other purposes.
- 3.18. **Qualified End-user (QE)** refers to entities that generate electric power from an eligible on-site RE generating facility, such as, but not limited to, house or office building with photovoltaic system that can be connected to the grid, for the purposes of entering into a Net-Metering agreement, as defined in Section 7 of the Implementing Rules and Regulations of R.A. 9513.
- 3.19. **Reclosing** refers to the automatic return of power lines to service following their disconnection for fault conditions.
- 3.20. **Renewable Energy (RE) Certificate** refers to a certificate issued by the RE Registrar to electric power industry participants showing the energy sourced, produced, and sold or used. RE Certificates may be traded in the RE Market in complying with the RPS, as defined in Section 3(tt) of the Implementing Rules and Regulations of R.A. 9513.
- 3.21. **Renewable Energy Facility (RE facility)** refers to the generator(s) and/or inverter(s) together with all protective, safety, and associated equipment located on the QE's side

of the Connection Point which the QE requests to interconnect to the DU's Distribution System.

3.22. **Renewable Energy Resources (RE Resources)** refers to energy resources that do not have an upper limit on the total quantity to be used. Such resources are renewable on a regular basis, and whose renewal rate is relatively rapid to consider availability over an indefinite period of time. These include, among others, biomass, solar, wind, geothermal, ocean energy, and hydropower conforming with internationally-accepted norms and standards on dams, and other emerging renewable energy technologies, as defined in Section 4(uu) of Republic Act No. 9513.

3.23. **Standard Planning Data** refers to the general data required by the distribution utility as part of the application for a net-metering interconnection.

3.24. **Synchronization** refers to the process of attaining the state when connected Generating Units and/or interconnected AC Systems operate at the same Frequency and where the phase angle displacements between their voltages vary about a stable operating point.

4. GENERAL GUIDELINES

4.1. A QE who intends to operate in parallel with the DU's Distribution System shall, in consultation with the DU, design, install, operate, and maintain all necessary equipment on its property for interconnection, unless otherwise stated in the Net-metering Agreement.

4.2. The requirements in these guidelines shall be met at the Connection Point, although the devices used to meet these requirements can be located elsewhere.

4.3. The DU shall only allow interconnection of RE facilities with a maximum capacity of 100 kW to the DU's Distribution System per QE account.

4.4. The DU shall conduct inspections and witness calibration and testing of the QE's lines, wires, and switches and shall remove the QE's generation from the Distribution System at any time due to maintenance, test, repair, and emergency condition or safety concerns related to the DU.

- 4.5. All specifications and detailed plans for the installation of the communication, control and protective devices shall be of the DU's standards.
- 4.6. The QE shall inform and seek the approval of the DU prior to the execution of any changes or modifications in the RE facility or to the connection point and shall be liable for any costs and/or damages incurred by the DU as a result thereof.
- 4.7. The RE facility shall conform to the latest revision of the PEC, PDC, DSOAR, other local codes, and the Terms and Conditions of Service and Standard Rules and Regulations as approved by the ERC.

5. APPLICATION FOR INTERCONNECTION

- 5.1. Upon written request, the DU shall provide information and documents (such as the *pro forma* agreements and the application, technical requirements, specifications, listing of certified equipment, application fee information, applicable rate schedules and metering requirements) in response to a QE's inquiry. All such information shall be sent to the QE as agreed upon by the DU and the QE.
- 5.2. The application form shall include the following information:
 - A description of the proposed connection or modification to an existing connection to the Distribution System;
 - The relevant Standard Planning Data as specified in Section 6.4 of the PDC, and other data as required by the DU; and
 - The completion date of the proposed interconnection.
- 5.3. The QE shall complete and file an application and any possible Detailed Planning Data as specified in Section 6.5 of the PDC. The filing must include the completed application and a fee (if required) for processing the application.
- 5.4. Within ten (10) business days upon receiving the application, the DU shall acknowledge its receipt and state whether or not the application is complete.

- 5.5. Once an application is accepted by the DU as complete, the DU shall determine on a non-discriminatory basis whether or not a specific DIS and/or DAS are necessary in accordance with the DSOAR.
- 5.6. Upon completion of the study, the DU shall provide the applicant with the results of the study, including any additional interim agreements, such as construction agreements that may be necessary and a cost estimate to complete the interconnection.
- 5.7. Prior to signing of the Net-metering Agreement, the DU, together with the QE, shall inspect the RE facility onsite and check its conformance to the technical requirements in the Net-metering Agreement and of these guidelines. Any non-conformance shall be corrected first before the Net-metering Agreement is signed and the RE facility is connected and energized.
- 5.8. The DU and QE, taking into consideration the agreed target completion date, shall use their reasonable endeavors, in coordination with each other, to complete their respective connection arrangements as agreed in the Net-metering Agreement.

6. SYSTEM PARAMETERS

Any RE facility causing interference, problems, or any unacceptable parameters to the DU's Distribution System shall be disconnected from the Distribution System and shall remain disconnected until the condition has been corrected. If the cause of the problem is the RE facility, all costs associated with determining and correcting the problem shall be at the QE's expense.

6.1. Voltage Level

The QE shall operate its facility to maintain the same voltage level as the DU's Distribution System at the Connection Point. The QE must provide an automatic method of disconnecting its facility from the Distribution System within DU's limits as stated in Table 1.

Table 1 – Minimum Time Requirements for RE to Remain Connected at Different Voltage Ranges

Voltage Range (% of Base Voltage)	Time (s)
V<30	0.15
V=30	0.6
30<V≤90	Linear interpolation between 0.60 second at 30% of base voltage and 3.0 seconds at 90% base voltage
90<V ≤110	Continuous Operation
110<V<120	1.00
V≥120	0.16

6.2. Frequency

All RE facility shall operate at a frequency of 60 Hz. The QE shall provide automatic disconnecting means from the DU's Distribution System within the time prescribed in Table 2.

Table 2 - Minimum Time Requirements for RE to Remain Connected at Different Frequency Ranges

Frequency Range (Hz)	Time
F > 62.4	Automatic disconnection allowed, if so decided by the VRE operator.
61.8 < F ≤ 62.4	5 minutes
58.2 ≤ F ≤ 61.8	Continuous Operation
57.6 ≤ F < 58.2	60 minutes
F < 57.6	5 seconds

6.3. Power Quality

6.3.1. Limitation of DC Injection

The RE facility and its interconnecting system shall not inject DC current greater than 0.5% of the full load rated output current at the Connection Point.

6.3.2. Flicker Severity

The flicker severity at the Connection Point shall not exceed 1.0 unit for short term and 0.8 units for long

term as specified in Section 3.2.6 of the PDC, or any amendments thereto.

6.3.3. Harmonics

The harmonic content of the voltage and current waveforms in the DU's Distribution System shall be restricted to levels that will not cause interference or equipment-operating problems. The harmonics shall be within the limits defined in Section 3.2.4 of the PDC or any amendments thereto.

6.4. Power Factor

The QE shall maintain a power factor of not less than 85% lagging measured at the Connection Point. Failure to maintain the power factor within this range may result in rate penalties and/or discontinuation of interconnection with the DU's Distribution System.

7. SYSTEM PROTECTION

The QE shall be responsible for providing adequate protection for its facility under any operating conditions, and regardless of whether or not the interconnected generation is in operation. Conditions include, but are not limited to, single phasing of supply, system faults, equipment failures, abnormal voltage or frequency, lightning and switching surges, excessive harmonic voltages, excessive negative sequence voltages and islanding.

7.1. Synchronization

The QE shall provide synchronizing devices for synchronizing the RE facility to the DU's Distribution System. Automatic synchronization devices shall be installed to monitor and control the synchronism, frequency, power factor and the voltage level of the RE facility. The DU shall review, approve, and inspect the method of synchronization. Automatic synchronizing settings shall not be changed following installation unless mutually agreed by both parties. Typical limits for synchronizing parameters are given in Table 3.

Table 3 - Typical Synchronizing Parameter Limits

Aggregate Rating of RE Resource (kW)	Maximum Frequency Difference Δf (Hz)	Maximum Voltage Difference ΔV (%)	Maximum Phase Angle Difference $\Delta \Phi$ (Degrees)
≤ 100	0.3	10	20

7.2. Islanding

To prevent islanding, in which the RE facility energizes a portion of the DU's Distribution System through the Connection Point, the QE's interconnection system should detect islanding and should disconnect from the Distribution System within two seconds from the formation of an island. The QE shall provide facilities against islanding to isolate and block the RE facility from closing back into the Distribution System until the system is energized for several minutes from the normal utility source.

7.3. Integration with DU's Distribution System Grounding

The grounding scheme of the QE shall not cause over voltages that exceed the rating of the equipment connected to the DU's Distribution System and shall not disrupt the coordination of the ground fault protection on the Distribution System. All electrical systems and equipment shall be grounded in accordance with the requirements of the PEC.

7.4. Protective and Control Devices

The QE's protection system shall coordinate with the DU's protection system. The QE shall submit proposed fused types or relay settings to the DU for review and acceptance. Any subsequent relay changes shall also be submitted to the DU.

7.4.1. Disconnect Device

The QE shall provide a visible disconnect device for use by the DU to electrically isolate the DU's Distribution System from the RE facility and to establish working clearances for maintenance, safety and system considerations. The disconnect device shall be physically located for ease of access by the DU personnel located within 10 feet from the

Connection Point. If this is not practical, the disconnect device should be located between the RE facility and the Connection Point. The type of disconnect device must allow for visual indication of the contact's position and the handle must be lockable in the open position with a padlock. It shall be readily accessible at all times by the DU personnel.

Labels, markings and warning signs shall be applied near the Connection Point to alert DU personnel of an RE facility installed within the QE's premises.

7.4.2. Protective Relays

Protective relays shall be installed to trip the corresponding circuit breaker during abnormal conditions. Protective relays for a given RE Resource rating typically include, but are not limited to, the lists shown in Tables 4, 5 and 6.

Table 4 - Interconnection Protective Function Requirements for Induction Generators

Device #	Protective Equipment	Generator Size	
		≤ 20 kW	>20 kW - 100 kW
27	Under-voltage Relay	x	x
27 GEN	Voltage Check Relay	x	x
59	Over-voltage Relay		x
81/O, 81/U	Over/Under Frequency Relay		x

Table 5 - Interconnection Protective Function Requirements for Synchronous Generators

Device #	Protective Equipment	Generator Size		
		≤ 8 kW	>8 - 20kW	>20 - 100 kW
25	Synchronism-Check Relay	x	x	x
27	Under-voltage Relay	x	x	x
51V	Over-current Relay, Voltage Restrained			x
59	Over-voltage Relay		x	x
81/O, 81/U	Over/Under frequency Relay		x	x

Table 6 - Interconnection Protective Function Requirements for Inverters

Device #	Protective Equipment	Inverter Size
		≤ 100 kW
27	Under-voltage Relay	x
59	Over-voltage Relay	x
81/O, 81/U	Over/Under Frequency Relay	x

7.5. Reclosing

The RE facility should immediately disconnect from the Distribution System when the system is down. For a Distribution System with automatic reclosing, the RE facility should wait for 2 minutes until the recloser has normalized the portion of the system to which the RE facility is connected before synchronizing back to the system.

8. OPERATIONS & MAINTENANCE

- 8.1. A QE's RE facility shall be capable of operating in parallel with the DU's Distribution System at the point of interconnection.
- 8.2. The QE must inform the DU's System Operator if it is going to synchronize to or isolate from the DU system.
- 8.3. In the event there is no power from the DU, the RE facility should automatically disconnect from the DU's system.
- 8.4. The QE shall provide the DU the contact number of the person who is responsible for the operation of the RE facility.
- 8.5. The QE shall also maintain the RE facility and interconnection facilities in a safe manner as approved by the DU and in conformity with all applicable laws, rules and regulations.

9. METERING

- 9.1. An RE facility used for Net-Metering shall be equipped with metering equipment that can measure the flow of electricity in both directions at the same rate, through the use of either two uni-directional meters, one for import and one for export,

or single bi-directional meter, whichever is more economical on a case-to-case basis.

- 9.2. A generation check meter may be installed in proximity to the RE facility (at low voltage side) to record all energy production of the RE facility for purposes of issuance of RE Certificate, which the DU can use to comply with its RPS obligations.
- 9.3. The Metering Service Provider (MSP) shall own and shall be responsible for the design, provision, installation, operation, maintenance, testing and sealing of the meter and associated metering equipment in accordance with Section 2.11 of the DSOAR.
- 9.4. The QE shall provide the required space and the associated civil works for the location of the metering facilities.
- 9.5. Metering facilities shall be installed in a clean place free of vibration and where it will be easily accessible and visible for reading and testing by both the DU and the QE. The applicable provisions of the DSOAR and Magna Carta for Residential Electricity Consumers shall apply.

10. TESTING AND COMMISSIONING

The DU shall have the right to witness the testing and commissioning upon completion of construction and shall have a copy of the test data. The commissioning test shall be conducted after the interconnection system is installed and is ready for operation. Commissioning test shall include the following:

- Verification and inspections
- Production test
 - Response to abnormal voltage
 - Response to abnormal frequency
 - Synchronization
- Unintentional islanding functionality test
- Cease-to-energize functionality test

The RE facility shall be equipped with whatever equipment is required to perform this test. The DU shall not be responsible for verifying any control or signal wiring not directly related to the interconnection protection.

Prior to final approval by the DU or any time thereafter, the DU reserves the right to test the relaying and control related to the protection of the DU's Distribution System.

11. BIBLIOGRAPHY

Republic Act No. 9513. Renewable Energy Act of 2008.

Philippine Electrical Code (PEC) Part I. Institute of Integrated Electrical Engineers of the Philippines, Inc., 2000.

Philippine Electrical Code (PEC) Part II. Institute of Integrated Electrical Engineers of the Philippines, Inc., 2008.

Philippine Distribution Code (PDC). Energy Regulatory Commission, December 2001.

Distribution Services and Open Access Rules (DSOAR). Energy Regulatory Commission, January 2006.

IEEE Std. 519-1992 - IEEE Recommended Practices and Requirements for Harmonic Control in Electrical Power Systems. Institute of Electrical and Electronics Engineers, Inc., 1992.

IEEE Std. 929-2000 - IEEE Recommended Practice for Utility Interface of Photovoltaic (PV) Systems. Institute of Electrical and Electronics Engineers, Inc., 2000.

IEEE Std. 1547 – 2003 (R2008), IEEE Standard for Interconnecting Distributed Resources with Electric Power Systems. Institute of Electrical and Electronics Engineers, Inc., 2008.

IEEE Std. 1547.1 – 2005, IEEE Standard Conformance Test Procedures for Equipment interconnecting Distributed Resources with Electric Power Systems. Institute of Electrical and Electronics Engineers, Inc., 2005.

IEEE Std. 1547.2 – 2007, IEEE Application Guide for IEEE Std. 1547, IEEE Standard for Interconnecting Distributed Resources with Electric Power Systems. Institute of Electrical and Electronics Engineers, Inc., 2007.

The NRECA Guide to IEEE 1547, Application Guide for Distributed Generation Interconnection. National Rural Electric Cooperative Association, March 2006.

Relay and Control Requirements for Parallel Operation of Generation. PPL, Electric Utilities Corp., Inc., March 2003.

*IREC Model Interconnection Standards and Procedures for Small
Generator Facilities.* Interstate Renewable Energy Council MR-I
2005

12. APPENDIX

Appendix A - Typical Single-Line Diagram for the Protection of Synchronous Generator

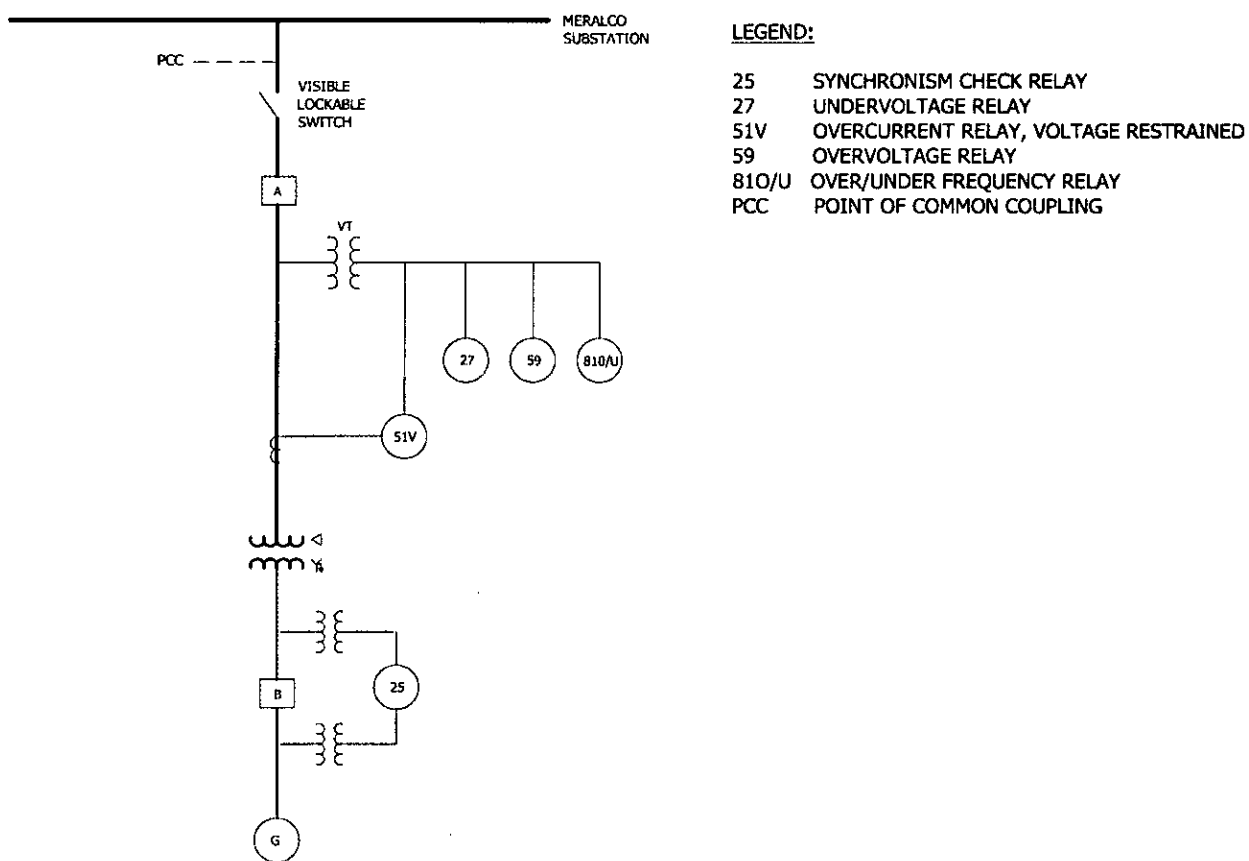

Appendix B - Typical Single-Line Diagram for the Protection of Induction Generator

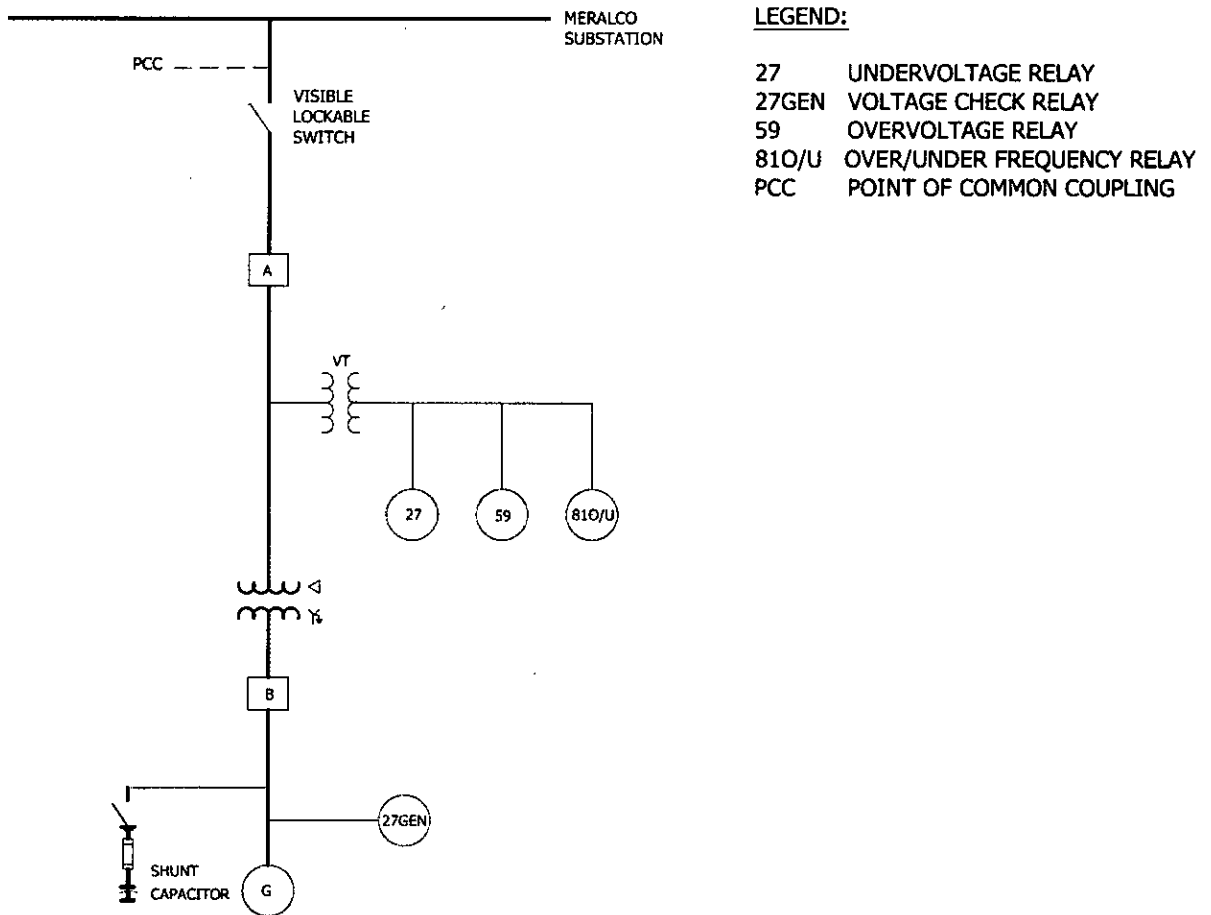

Appendix C - Typical Single-Line Diagram for the Protection of Inverter

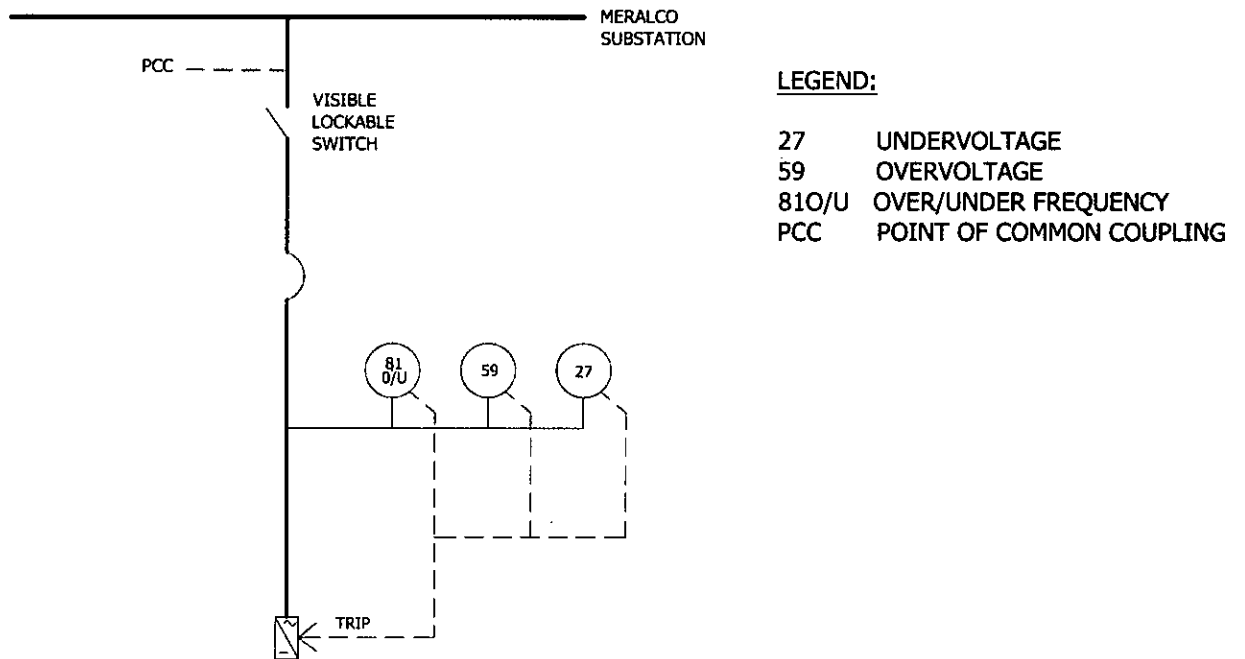

NET-METERING AGREEMENT

This **Net-metering Agreement** is entered into by and between:

[redacted], of legal age,
single/married, with [redacted] postal address at
[redacted], hereinafter referred
to as the Qualified End-User (QE);

-and-

[redacted], an electric
distribution utility duly organized and existing
under Philippine law, with principal office
address at [redacted],
franchised to construct, own, operate and
maintain an electric distribution facility in the
city/municipalities/barangays of
[redacted], all in the
Province of [redacted],
represented herein by its President/General
Manager [redacted],
hereinafter referred to as the DU;

WITNESSETH THAT:

WHEREAS, QE intends to install within its premises for purposes of net-metering a Renewable Energy (RE) facility, more particularly described as follows:

Technology Type: _____
Rated Capacity: _____
Location: _____

WHEREAS, DU has pre-qualified QE to be eligible to participate in the net-metering program;

NOW, THEREFORE, the parties enter into this net-metering agreement under the following terms and conditions:

Section 1. Compliance Standards. - The RE System to be installed within the QE's premises must be compliant with the standards set by Philippine Electrical Code (PEC), Philippine Distribution Code (PDC),

Distribution Service Open Access Rules (DSOAR) and the Net-Metering Interconnection Standards.

Section 2. Interconnection Set-Up. - The RE facility shall be embedded in the QE's premises and shall be equipped with appropriate metering equipment.

- a. The DU shall install, own, operate and maintain two uni-directional meters, one for import and one for export, or single bi-directional meter, whichever is more economical on a case-to-case basis.
- b. The DU may, at any time, also install a third meter in proximity to the RE System to measure the total RE generated.

A complete and more detailed plans and specifications of the interconnection set-up and facilities are attached as an integral of this net-metering agreement.

Section 3. DU Inspection. - The QE shall allow the DU to enter the QE's premises to inspect, test, maintain and operate the protective devices and read or test the meters and other facilities. The DU may also disconnect the interconnection facilities if it reasonably believes a hazardous condition exists and such immediate action is necessary to protect persons, or the DU's facilities or property of others, against damage or interference caused by the QE's facilities, or lack of properly operating protective devices; provided, that prior notice is given of the intent to disconnect, and the QE is given at least three (3) days within which to remedy the hazardous condition.

Section 4. Meter Readings. - The DU shall be the Metering Service Provider and shall conduct the meter reading of the import and export meters every ___ day of the month for billing purposes. The DU shall immediately leave a copy of the results of its meter readings at the QE's premises, in accordance with Section 2.11.2 of the Distribution Services and Open Access Rules (DSOAR).

Section 5. Pricing of Exported Renewable Energy. – The DU's blended generation cost shall be used as the price of the renewable energy exported by the QE's RE facility to the DU's distribution system. The DU's blended generation cost shall be computed in accordance with the methodology prescribed in the Rules Enabling the Net-Metering for Renewable Energy issued by the Energy Regulatory Commission (ERC).

In the event that the ERC approves a pricing methodology applicable to net-metering, such pricing methodology shall automatically substitute as the price of renewable energy exported by the QE to the distribution system.

Section 6. Net-Metering Charge - The DUs shall impose a net-metering charge to all customers who avail of the Net-Metering program equivalent to their existing ERC-approved Php/customer/month supply and metering rates; plus the existing ERC-approved Php/kilowatt-hour metering rate based on the export energy to the Distribution System as registered in the export meter. This Net-Metering Charge shall cover the DU's incremental costs related to system enhancement and additional meter reading and other operating costs.

The DUs may file with the ERC their applications for approval of different Net-Metering Charges for Net-Metering customers in accordance with Section 4 (e), Rule 3 of the Implementing Rules and Regulations of Republic Act No. 9136 and Rule 6 of the ERC Rules of Practice and Procedure. Meantime, the Net-Metering Charges as provided above shall be effective until a different charge is approved by the ERC, upon application by the DUs.

Section 7. Billing Charges. The net amount payable by or creditable to the QE shall be obtained by subtracting from the subtotal amount for import energy, the following: (a) the subtotal peso amount for export energy, and (b) the peso amount credited in the previous month, if any. If the resulting peso amount is positive, QE shall pay this positive peso amount to the DU. If the resulting peso amount is negative, the DU shall credit the negative peso amount to the QE's electric bill in the immediately succeeding billing period.

Section 8. Termination Date. – The agreement shall be co-terminus with the service contract of the QE with the DU under Customer Account No. [_____]. Either party may however pre-terminate this net-metering agreement for just cause.

Section 9. Dispute Resolution. – In case of dispute over the application of certain provisions of this agreement, the parties shall exert best efforts to resolve the dispute among themselves within thirty (30) days from when the dispute arose. If the dispute remains unresolved after the thirty (30) day period, either party may file a petition for dispute resolution with the Energy Regulatory Commission (ERC), who shall have original and exclusive jurisdiction over such

dispute.

While these are pending with the ERC, the status quo of cases involving violation of contract shall be maintained. The maintenance of the status quo shall only be applicable to the subject matter of the case and will not extend to any other right/s and obligation/s between the parties

IN WITNESS WHEREOF, the parties execute this Net-Metering Agreement this (date) at (place).

**ABC Electric
Company/Cooperative
(DU)**

By:
President/General Manager

Juan Dela Cruz
Qualified End-User

Witnesses:
